

Product Data Sheet



135X701

Power Distribution Block –
Splicer Type
UL Listed
Category QPQS
475 Amps, 600 Volts (AC/DC)



Provides Feeder Circuit Terminal Spacing up to 600 Volts per UL 508A, Section 10.

Wire Range:

Line Side: (1) 750kcmil – 1/0 AWG
Load Side: (1) 750 kcmil – 1/0 AWG

[See tables below for SCCR wire ranges, flexible stranded and multiple wire approvals.](#)

Electrical Ratings:

- 475A copper wire, 385A aluminum wire (Based on NEC Table 310-16, 75°C columns)
- UL Voltage Rating: 600 Volts AC/DC (UL 1953)
- Factory and Field Wiring

Agency Certifications:

- UL Listed, Investigated to UL 1953, File QPQS.E309401
- RoHS Compliant

Short Circuit Current Ratings:

SCCR Rating applies for Copper Stranded wire only
UL Class B, C (known as Rigid Stranded, Building Wire, Code Wire)
UL Class G, H, I (Flexible Stranded, includes DLO)

Suitable Conductors (kcmil/AWG) Copper, Stranded				Overcurrent Protection Class/Max Amp Rating					SCCR, RMS SYM Amps	Volts Max
Line		Load								
Size	Class	Size	Class	J	T	RK1	RK5	G		
750 - 1/0	B,C	750 - 1/0	B,C	600	1200	600	400	60	100,000	600
535-1/0	G, H, I	535-1/0	G, H, I	600	700	600	200	60		

For DC power or any wire combinations or Overcurrent Protection not shown- SCCR is 10,000A

Minimum Enclosure Size: 20" x 24" x 8" (3840 cu. In)

Mechanical Ratings:

- Maximum insulator base temperature: 125°C (257°F) UL RTI
- Flammability rating of insulator base: UL 94 V-0

Materials:

- Connector: High conductivity aluminum, tin plated
- Insulator base: Glass filled polycarbonate (thermoplastic)
- Terminal screws: Aluminum, tin plated
- Connector mounting screw: Steel, zinc plated

Wire Ranges, Wire Types, Torque Ratings: 135X701

UL Class B, C (known as Rigid Stranded, Building Wire, Code Wire)

UL Class G, H, I (Flexible Stranded, includes DLO)

Line Side 1) 750 kcmil - 1/0 AWG

Copper Conductor			
Wire Size	Torque		UL Class
kcmil - AWG	N.m	in. lbs	
750 - 1/0	67.8	600	B, C
535 - 1/0	67.8	600	G,H, I
Aluminum Conductor			
Wire Size	Torque		Type
kcmil - AWG	N.m	in. lbs	
750 - 1/0	67.8	600	Stranded

Load Side 1) 750 kcmil - 1/0 AWG

Copper Conductor			
Wire Size	Torque		UL Class
kcmil - AWG	N.m	in. lbs	
750 - 1/0	67.8	600	B, C
535 - 1/0	67.8	600	G,H, I
Aluminum Conductor			
Wire Size	Torque		Type
kcmil - AWG	N.m	in. lbs	
750 - 1/0	67.8	600	Stranded

Installation:

- Wire strip length, line and load side tap – 1 ¾"
- Panel mountable: recommended fastener (4) per pole, ¼ " or 6mm Torque to 30 in. lbs. (3.4 N.m)

750 kcmil wire opening- diameter 1.125" (28.5 mm)

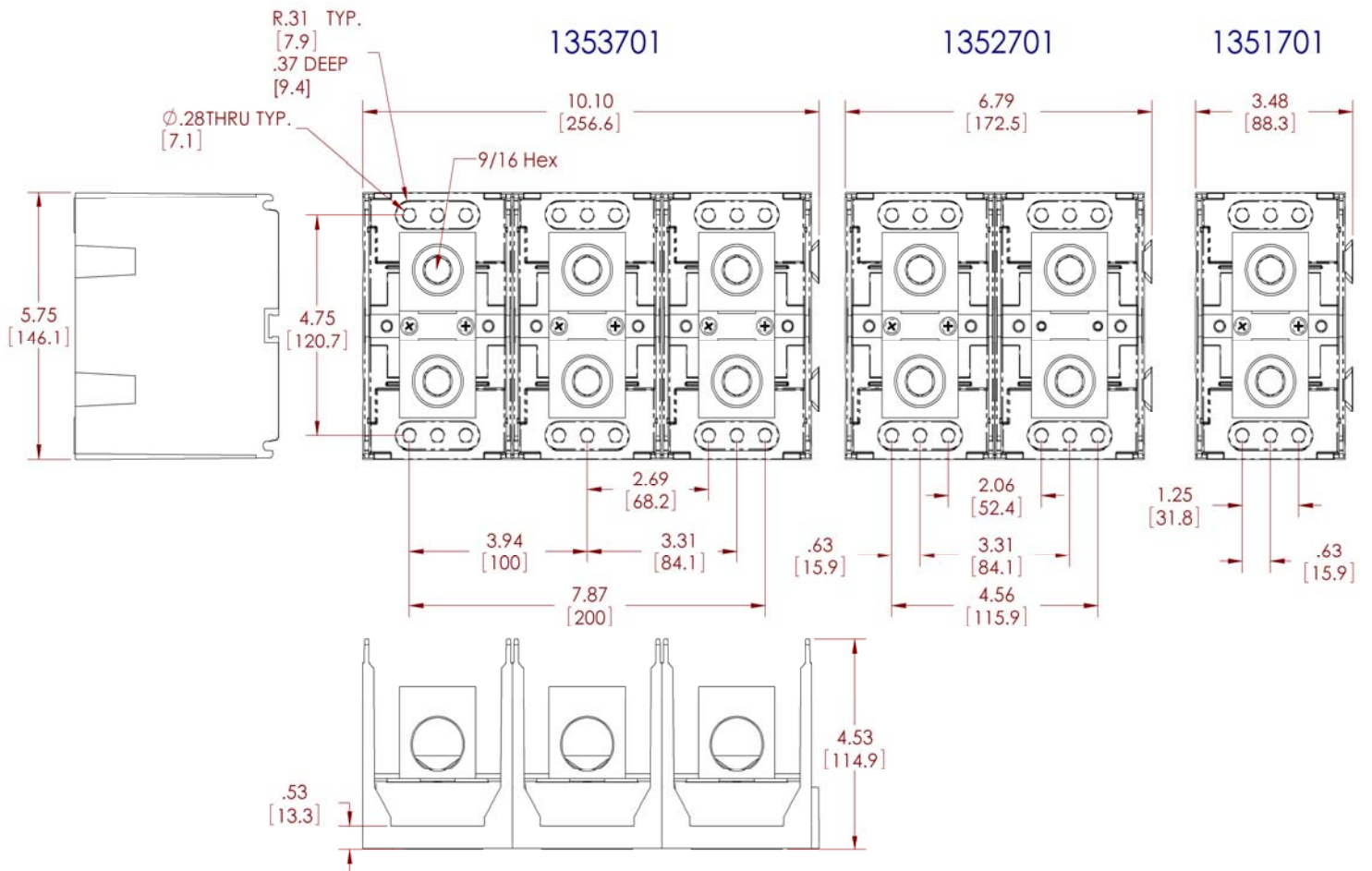

WWW.MARATHONSP.COM
 1-419-352-8441