

Product Data Sheet



EPBAD71

Enclosed Splicer Power Block
510 Amps, 600 Volts (AC/DC)
800V AC/DC CE (IEC 60947-7-1)



Wire Range:

Line side: (2) 250kcmil - #6 AWG (120 mm² - 16 mm²)
Load Side: (2) 250kcmil - #6 AWG (120 mm² - 16 mm²)

Electrical Ratings:

- 510A copper wire, 410A aluminum wire (Based on NEC Table 310-16, 75°C columns)
- **CE** Rated Voltage (U_i): 800 V AC/DC per IEC 60947-7-1
- Rated Impulse Voltage (U_{imp}): 6,000V
- Material Group: IIIa
- Pollution Degree: 3
- UL/CSA Voltage Rating: 600 Volts AC/DC (UL 1059 Class C, User Group - General Industrial)
- Factory and Field Wiring

Mechanical Ratings:

- Maximum insulator base temperature: 125°C (257°F) UL RTI
 - Storage and transportation temperature range: -35°C to 110°C (-31°F to 230°F)
 - Flammability rating of insulator base: UL 94V-0
 - Touch protection: IP-20 (IEC 60529) with following conditions: Restricted wire range. See "Wire Approvals" table below for wire ranges to achieve IP-20 rating. Safety plugs are required for unused taps. See "Accessories" below for safety plugs.
- * Use outside these ratings needs to be judged in the end-use application.

Materials:

- Connector: High conductivity aluminum, tin plated
- Insulator base: glass filled polycarbonate (thermoplastic)

- Terminal set screws: Aluminum, Tin plated
- Connector mounting screw and roll pins: Steel, zinc plated

Agency Approvals:

- UL Recognized, UL 1059 Terminal Block Standard, File No. XCFR2.E62806
- CSA Certified, CSA C22.2 No. 158, File No. LR19766 (Wire Classes B & C only)
- CE compliant to IEC 60947-7-1
- RoHS Compliant

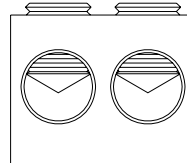

Wire Approvals:

Line and Load Wire Approvals:

		Copper Wire Stranding Classes - Number of Strands						
Wire Size	Torque	Solid	Class B	Class C	Class G	Class H	Class I	Class K
250 kcmil	275 in. lbs		37	61	~ 259	~ 427	~ 637	~ 2499
4/0	275 in. lbs		19	37	~ 133	~ 259	~ 532	~ 2107
3/0	275 in. lbs		19	37	~133	~ 259	~ 418	~ 1666
2/0	275 in. lbs		19	37	~133	~ 259	~ 342	~ 1323
1/0	275 in. lbs		19	37	~133	~ 259	~ 266	~ 1064
1	275 in. lbs		19	37	~ 133	~ 259	~ 210	~ 836
2	120 in. lbs		7	19	~ 49	~ 133	~ 161	~ 665
4	120 in. lbs		7	19				
6	120 in. lbs		7	19				

		Copper Wire Stranding Classes - Number of Strands		
Wire Size	Torque	Class 1	Class 2	Class 5
120 mm ²	31.07 N·m		37	614
95	31.07 N·m		19	485
70	31.07 N·m		19	356
50	31.07 N·m		19	400
35	13.56 N·m		7	280
25	13.56 N·m		7	
16	13.56 N·m		7	

Cells highlighted in green indicate wire ranges to maintain IP-20 rating.

Quantity of strands for Classes G, H, I, K and 5 may vary by manufacturer.

Aluminum stranded wire range: 250kcmil – 6 AWG (120-16 mm²)

- Wire strip length, line and load side tap – 1 3/8” (35 mm)
- 8 mm Allen hex drive for line and load side terminal screws. See “Accessories” for Allen wrenches that are recommended for this application.
- DIN rail mountable on 7.5 x 35 mm rail.
- Panel mountable: ¼” (M6) fastener, torque to 30 - 40 in. lbs (3.39 – 5.65 N·m).

Accessories:

- Safety plug: EPB Plug 250
- Marking Cards: White plastic inserts to mark circuits. Printing available consult factory.
- End Bracket: MSK35
- Allen wrenches:
 - S & K Tools 45958
 - Snap-On Tools FAML8E
 - MAC Tools XDLS8MM
 - McMaster-Carr 8367A26

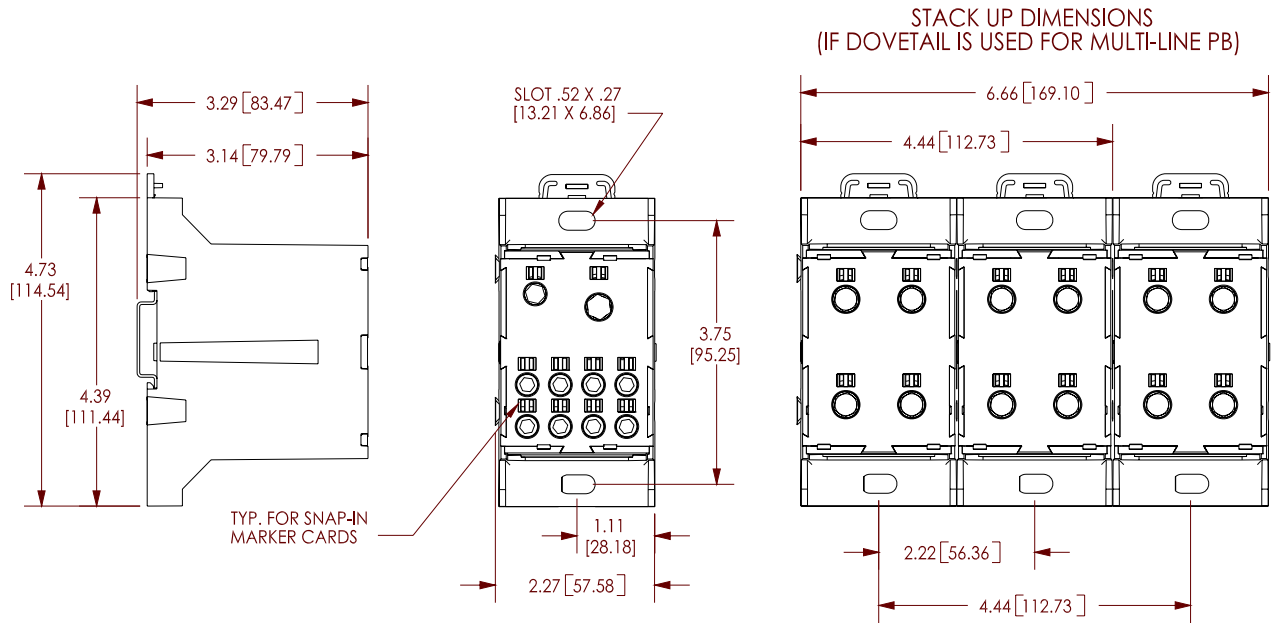

WWW.MARATHONSP.COM
1-419-352-8441